

MOTOX Geared Motors

Parallel shaft geared motors

Mounting types and mounting positions

Selection and ordering data

The mounting type / mounting position must be specified when you place your order to ensure that the gearbox is supplied with the correct quantity of oil.

Please contact customer service to discuss the oil quantity if you wish to use a mounting position which is not shown here.

Position of the terminal box

The terminal box of the motor can be mounted in four different positions. See Chapter 8 for an accurate representation of the terminal box position and the corresponding order codes.

2-stage and 3-stage parallel shaft gearbox, foot-mounted design, flange-mounted design, and with housing flange

Oil control valves:

- Size 28: These types are lubricated for life. No ventilation, oil level, or drain plugs are present.
 - Size 38B: V Oil inlet
 - From size 48B up:
 - Oil level
 - Ventilation
 - Oil drain
 - Oil dipstick
 - alternative
- ② 2-stage gearbox ③ 3-stage gearbox * On opposite side A,B position of the customer's solid/plug-in shaft

1 ... 4 Position of the terminal box, see Chapter 8.

F.Z, F.F: B5-01 (IM B5-01) ¹⁾
 Order code (output side A): **D22**
 F.AZ, F.AF: H-01 ¹⁾
 Order code (output side A): **D76**

1) Standard mounting type
 F.Z, F.F: B5-03 (IM B5-03)
 Order code (output side A): **D32**
 F.AZ, F.AF: H-02
 Order code (output side A): **D78**

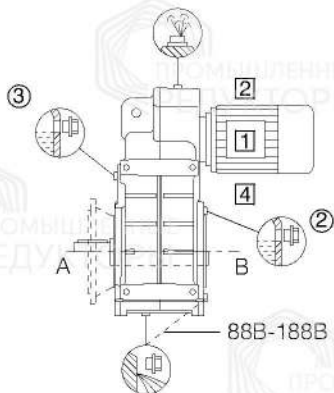

F.Z, F.F: B5-02 (IM B5-02)
 Order code (output side A): **D27**
 F.AZ, F.AF: H-03
 Order code (output side A): **D80**

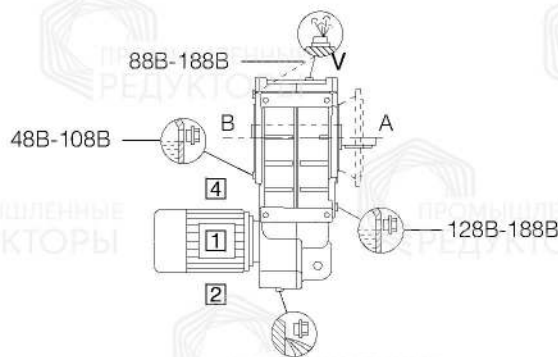
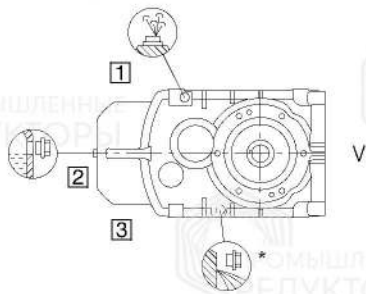

F.Z, F.F: B5-00 (IM B5-00)
 Order code (output side A): **D18**
 F.AZ, F.AF: H-04
 Order code (output side A): **D82**

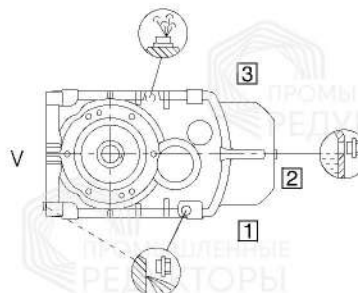

Selection and ordering data (continued)

2-stage and 3-stage parallel shaft gearbox, foot-mounted design, flange-mounted design and with housing flange

Oil control valves:

• Size 28: These types are lubricated for life. No ventilation, oil level, or drain plugs are present.

• Size 38B: V Oil inlet

• From size 48B up:  Oil level  Ventilation  Oil drain  Oil dipstick --- Alternative

② 2-stage gearbox ③ 3-stage gearbox * On opposite side A, B position of the customer's solid/plug-in shaft

① ... ④ Position of the terminal box, see Chapter 8.

F.Z, F.F: V1-00 (IM V1-00)
Order code (output side A): **D90**
F.AZ, F.AF: H-05
Order code (output side A): **D84**

F.Z, F.F: V3-00 (IM V3-00)
Order code (output side A): **D98**
F.AZ, F.AF: H-06
Order code (output side A): **D86**

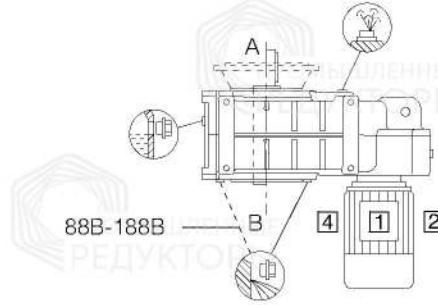
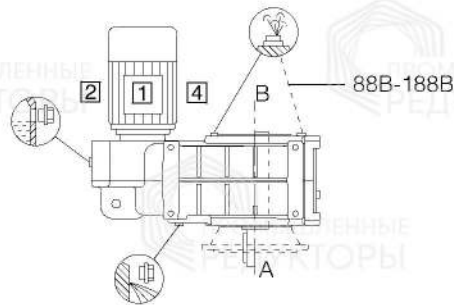

2-stage and 3-stage parallel shaft gearbox with mixer flange (FZ.M/FD.M)

Mounting positions correspond to those of standard gearboxes.

2-stage and 3-stage parallel shaft gearbox with extruder flange (FZAE/FDAE)

Mounting positions correspond to those of standard gearboxes with hollow shaft.

MOTOX Geared Motors





Parallel shaft geared motors

Mounting types and mounting positions

Selection and ordering data (continued)

2-stage and 3-stage parallel shaft gearbox, foot-mounted design, flange-mounted design, and with housing flange for size 208

Oil control valves:

-  Oil level
-  Ventilation
-  Oil drain
-  Oil dipstick
- Alternative

- ② 2-stage gearbox
- ③ 3-stage gearbox
- ④ Tandem gearbox * On opposite side A,B position of the customer's solid/plug-in shaft

1 ... 4 Position of the terminal box, see Chapter 8.

F.Z: B5-01 (IM B5-01) ¹⁾
 Order code (output side A): **D22**
 F.A.: H-01 ¹⁾
 Order code (output side A): **D76**

F.Z: B5-03 (IM B5-03)
 Order code (output side A): **D32**
 F.A.: H-02
 Order code (output side A): **D78**

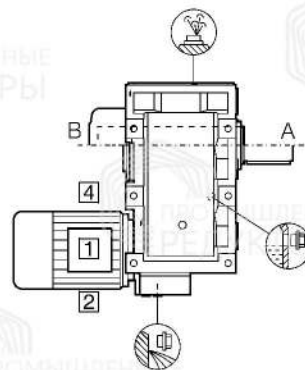
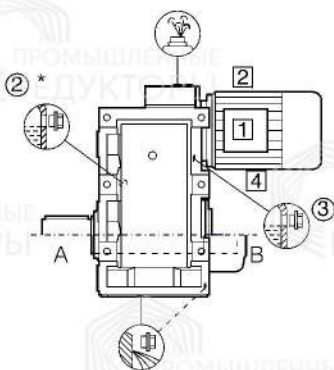

F.Z: B5-02 (IM B5-02)
 Order code (output side A): **D27**
 F.A.: H-03
 Order code (output side A): **D80**

F.Z: B5-00 (IM B5-00)
 Order code (output side A): **D18**
 F.A.: H-04
 Order code (output side A): **D82**

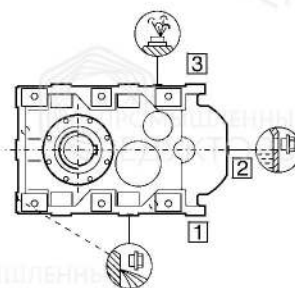
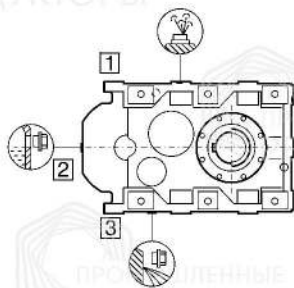

F.Z: V1-00 (IM V1-00)
 Order code (output side A): **D90**
 F.A.: H-05
 Order code (output side A): **D84**

F.Z: V3-00 (IM V3-00)
 Order code (output side A): **D98**
 F.A.: H-06
 Order code (output side A): **D86**

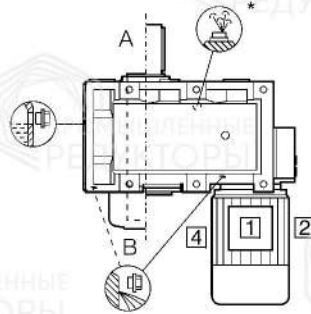
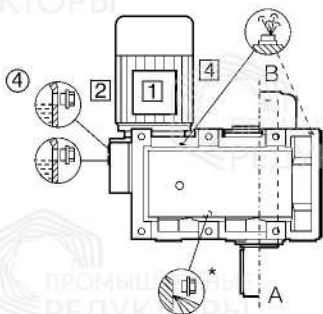

Selection and ordering data (continued)

Parallel shaft tandem gearbox

The mounting type / mounting position of the tandem gearbox corresponds to that of the main gearbox. The figures below are only designed to show the position of the oil control valves of the 2nd gearbox.

Note:

In a horizontal operating position the bulging part of the housing of the 2nd gearbox generally faces vertically downwards.

Oil control valves:

- Size 28/38 (2nd gearbox): These types are lubricated for life. No ventilation, oil level, or drain plugs are present.

- From size 48B up:  Oil level  Ventilation  Oil drain * On opposite side

② 2-stage gearbox

③ 3-stage gearbox

